

Distributed Intelligent Clean Air System

PRODUCT DESCRIPTION

smartIAQ is an Intelligent Clean Air System that provides demand-driven air cleaning of the 15 design compounds listed in ASHRAE standard 62.1-2019 and -2022 to achieve compliance with the Indoor Air Quality Procedure. smartIAQ is designed to offset the high cost of conditioning excess outdoor air; making systems less costly to deploy and operate, delivering real ROI; all the while ensuring indoor air quality meets current standards.

Operating independently of an HVAC system, smartIAQ is dedicated to ensuring clean air is delivered to the breathing zone when needed, with models configured to cover in up to 4 discrete zones. This allows the SIAQ-500 DC Series to facilitate the reduction of outside air ventilation allowing for the downsizing of HVAC equipment. Designed to be installed above a drop ceiling or in plenum returns, the system is also elegantly designed to look at home in an open ceiling application.

smartIAQ is powered by digital control, informed by a panel of solid state, calibrated, air quality sensors that manage the cleaned airflow, utilizing a minimum airflow in an idle state while sensing and ramping to cleaning speed when needed.

STANDARD FEATURES

- Integral EC Blower - varies from 100CFM in Monitor mode through to a Peak Clean flow of 500CFM.
- Quiet operation - Nominal 33 dB(A)
- 12" Dia inlet / outlet
- Easy tool-free filter access
- Integral hanger brackets for permanent installation using all thread rods
- NPBI Soft Ionization delivered in all operational modes
- Supports maximum external static pressure of 0.8" W.C.
- I/O :
 - Inputs: INHIBIT OPERATION
 - Outputs: POWERED ON (READY)
ACTIVELY CLEANING
FAULT
CHANGE FILTER

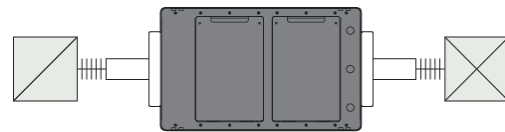
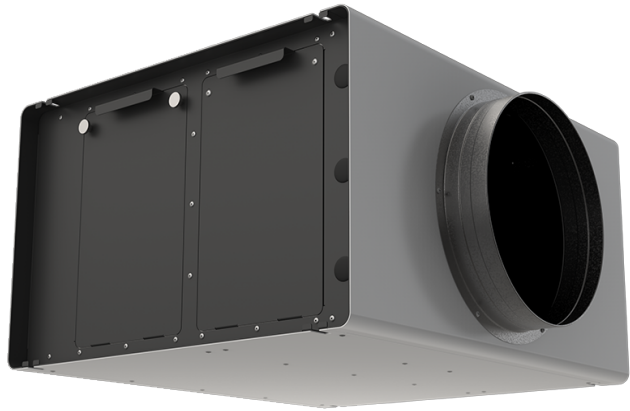

Standard Single Zone Deployment

MODEL CONFIGURATIONS

SIAQ-500-1I87	Single Zone Applications
SIAQ-500-2I87	2 Zone Applications
SIAQ-500-3I87	3 Zone Applications
SIAQ-500-4I87	4 Zone Applications

FILTRATION DETAILS

The SIAQ-500-1-DC utilizes high efficiency Particulate and Molecular filters to address defined design compounds.

Base Level Kits consist of the following:

Qty 1 (one) 2" MERV 14 Particulate
Model: SIAQ-PF14-12242

Qty %(cbY) 2" Molecular Filter
Model: SIAQ-MF1-12242

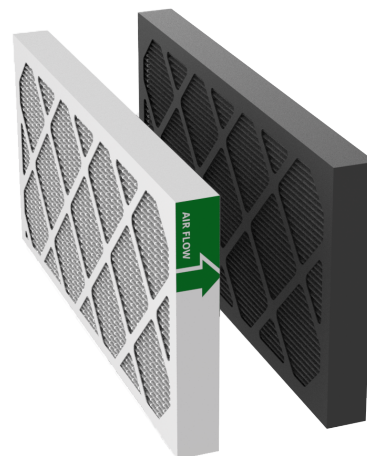

Unit achieves over 1 year of filter life*

*Based on ASHRAE published generation rates for design compounds

Distributed Intelligent Clean Air System

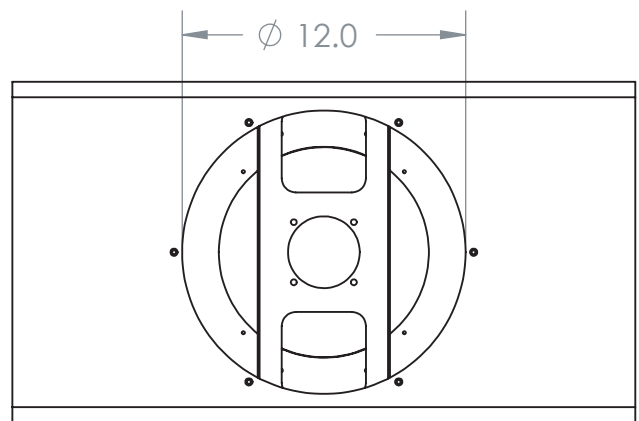
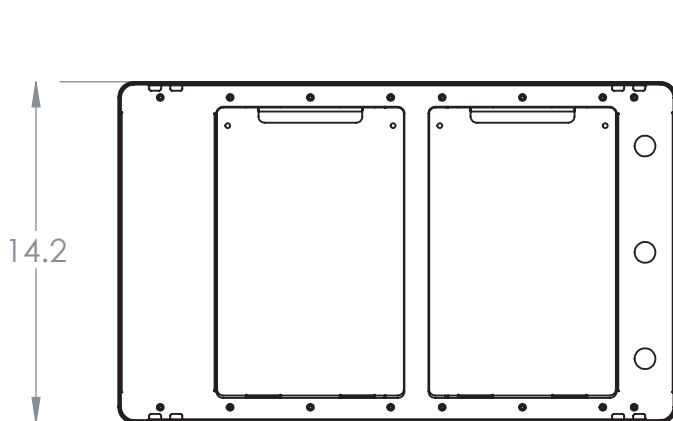
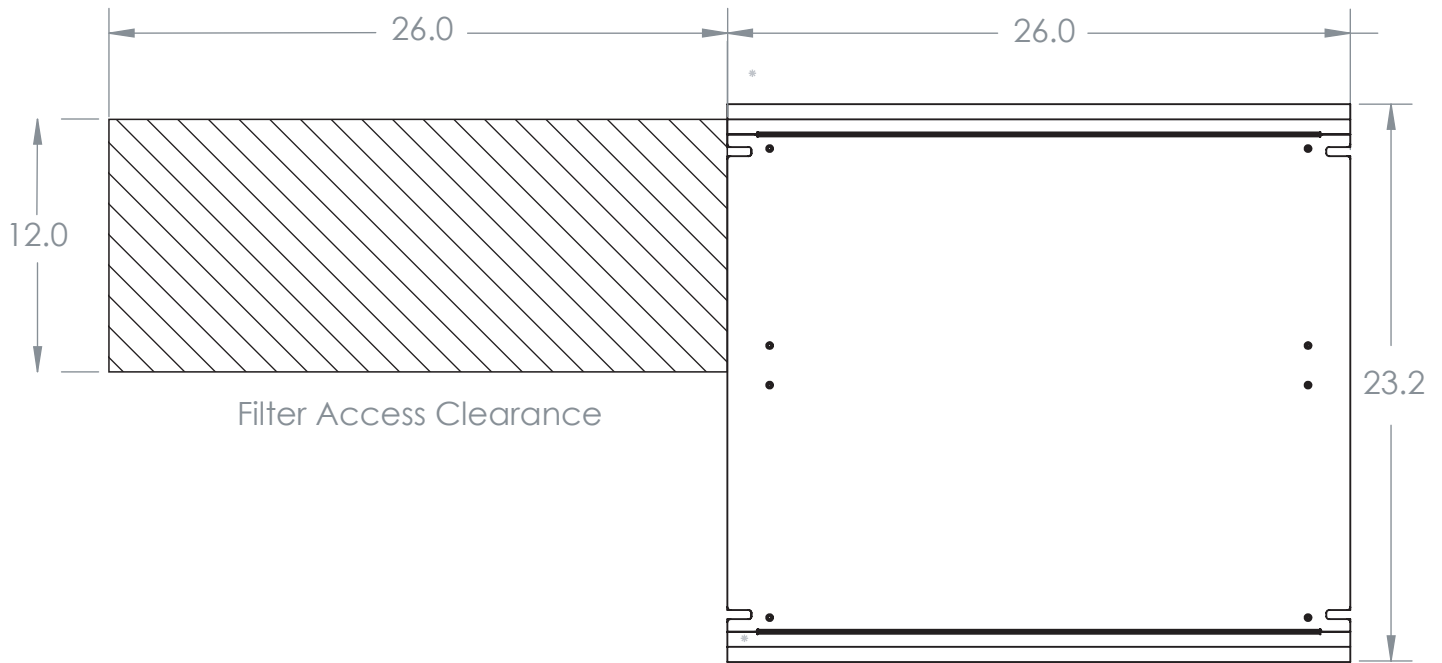

Service Side Elevation

Supply End Elevation

SIAQ-500-1-DC SPECIFICATIONS

Standard Input Voltage/Frequency	120 VAC, 50 / 60 Hz	Weight (Standard Unit)	70bs
Optional Input Voltage/Frequency	208/230/277/347 VAC, 50 / 60 Hz	Weight (with optional transformer)	78lbs
Airflow Capacity	500 CFM	Power Consumption	200 W (Max)
Sound Level (Sensing Mode)	NC-25	Temperature Range	0 - 140 F
Sound Level (Nominal Cleaning)	NC-35	Humidity Range	5 - 85% RH (non-condensing)
Filter Life	Over 1 year*	Compliance and Certifications	UL 507, UL 867, UL 2998
Unit Dimensions (L x W x H)	23" x 26" x 14"		