

Centralized Intelligent Clean Air System

PRODUCT DESCRIPTION

smartIAQ is an Intelligent Clean Air System that continuously cleans the air, addressing the 15 design compounds listed in ASHRAE standard 62.1-2019 and -2022 to achieve compliance with the Indoor Air Quality Procedure. smartIAQ is designed to offset the high cost of conditioning excess outdoor air; making systems less costly to deploy and operate, delivering real ROI; all the while ensuring indoor air quality meets current standards.

The smartIAQ SIAQ-700-1-CC integrates with a HVAC system drawing air from the return duct or plenum in a side stream configuration, before cleaning it and delivering it back to the air-stream. By addressing design compounds above and beyond simple comfort HVAC filtration, the SIAQ-700-1-CC facilitates the reduction of outside air ventilation allowing for the downsizing of HVAC equipment.

smartIAQ is informed by a panel of solid state, calibrated, air quality sensors that indicate prevailing air quality and support reporting of air quality concerns and filter end of life.

STANDARD FEATURES

- Integral EC Blower - varies from 100CFM in Monitor mode through to a Peak Clean flow of 700CFM.
- Quiet operation - Nominal 33 dB(A)
- 12" Dia inlet / outlet
- Easy tool-free filter access
- Integral hanger brackets for permanent installation using all thread rods
- Digital BMS integration via modbus RS-485
- Integrated universal voltage transformer
- Remote status indicator
- I/O :
 - Inputs: INHIBIT OPERATION
 - Outputs: POWERED ON (READY)
ACTIVELY CLEANING
FAULT
CHANGE FILTER

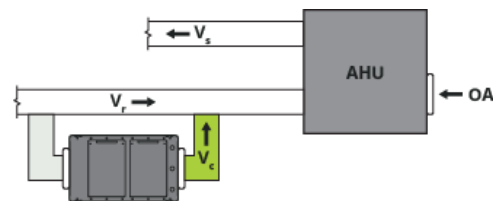
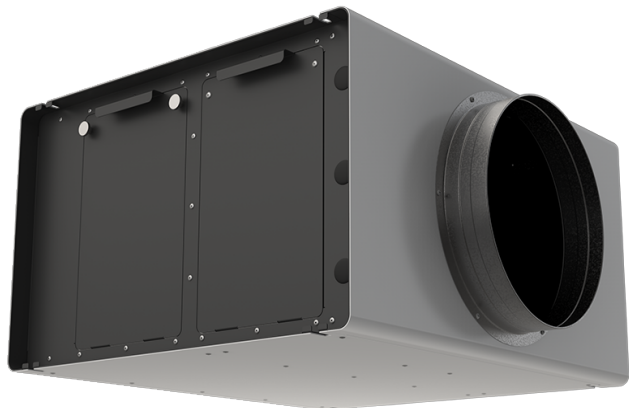

Standard Deployment

FILTRATION DETAILS

The SIAQ-700-1-CC utilizes high efficiency Particulate and Molecular filters to address defined design compounds.

Base Level Kits consist of the following:

Qty 1 (one) 2" MERV 14 Particulate Filter
Model: SIAQ-PF14-12242

Qty 2 (two) 2" Molecular Filters
Model: SIAQ-MF1-12242

Unit achieves 6 months of filter life*

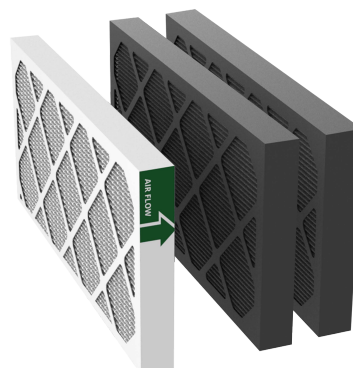

* Based on ASHRAE published generation rates for design compounds

Centralized Intelligent Clean Air System

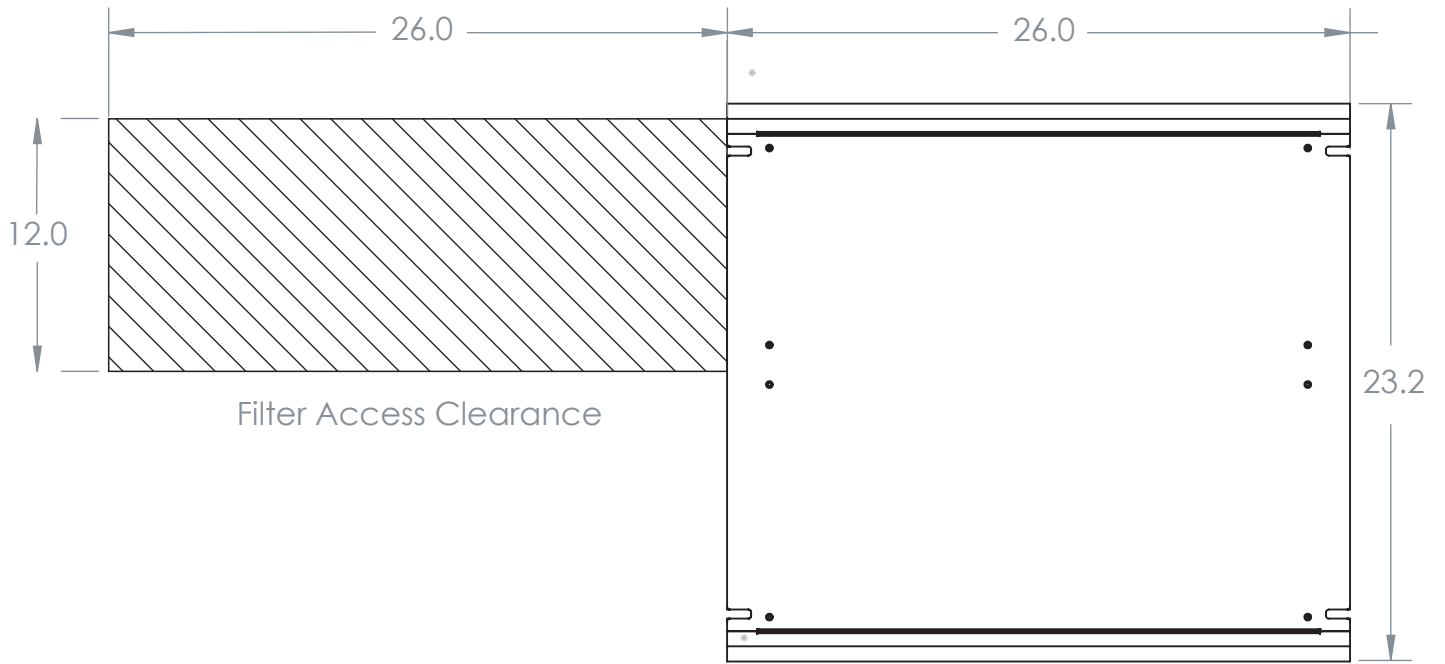

Filter Access Clearance

Plan View

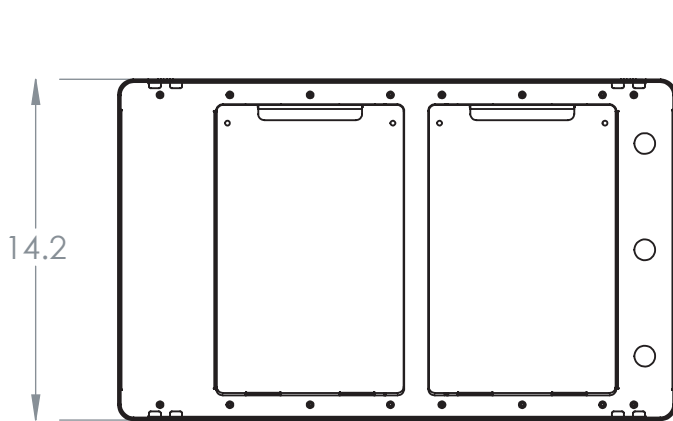

Service Side Elevation

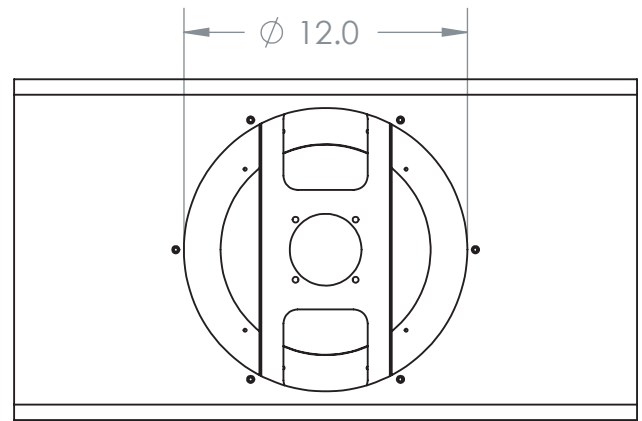

Supply End Elevation

SIAQ-700-1-CC SPECIFICATIONS

Standard Input Voltage/Frequency	120 or 208/230/277/347 VAC, 50 / 60 Hz	Weight (Standard Unit)	78lbs
Airflow Capacity	700 CFM	Power Consumption	200 W (Max)
Sound Level (Nominal Cleaning)	NC-35	Temperature Range	0 - 140 F
Filter Life	6 months*	Humidity Range	5 - 85% RH (non-condensing)
Unit Dimensions (L x W x H)	23" x 26" x 14"	Compliance and Certifications	UL 507, UL 867, UL 2998