

smartIAQ

GridSet Pro

Closed Loop Drop Ceiling Clean Air System

PRODUCT DESCRIPTION

smartIAQ® GridSet™ is an on-demand air cleaner for commercial spaces. It supports the easy application of the Indoor Air Quality Procedure (IAQP) by extracting design compounds listed in ASHRAE Standard 62.1-2019 and -2022. With low voltage power, occupant-based response, and low weight modules for “drop in” to ceiling grid systems, smartIAQ GridSet delivers immediate return on investment and supports ongoing savings with low service, installation, and design costs. Standard-sized filters and the smartIAQ operating system provide 2 years of maintenance-free operation. Status indicator, air quality sensor, and filter access are in the space, ensuring confident ownership and maintenance. Integrates with end-user BMS system

Suitable for classrooms, meeting rooms, retail stores, houses of worship, and some medical facilities, one smartIAQ GridSet cleans air in spaces up to 1,500ft². Multiple units may be used to help larger spaces achieve compliance.

STANDARD FEATURES

- Fan and Filter Modules
- Integral EC Blower - varies up to a Peak Clean flow of 150CFM to allow outdoor air reduction
- Virtually silent operation - NC25 at max flow
- Low weight modules for drop ceiling grids: does not require supplemental support (see IOM for more details)
- 48VDC low voltage power: uses CAT-5 or CAT-5e wiring to a smartIAQ Hub-4 Pro (separate device)
- Full BMS integration with native options for:
 - ✓ Modbus RTU - (via Hub-4 Pro)
 - ✓ BACnet MS/TP - (via Hub-4 Pro)
- Filter and operating profile provides closed loop for IAQP compliance
- Solid state motion and air quality sensors: no calibration or maintenance required:
 - ✓ Motion Sensor
 - ✓ CO₂ Sensor
 - ✓ Formaldehyde Sensor
 - ✓ PM Sensor (1.0, 2.5, 4.0 & 10.0)
 - ✓ TVOC Sensor
 - ✓ NO_x Sensor
- NPBI® Soft Ionization delivered to space at supply side



Single Zone

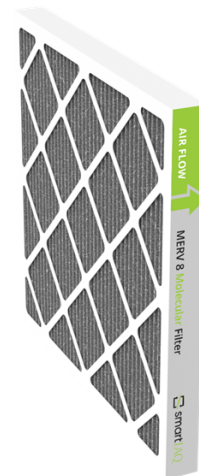
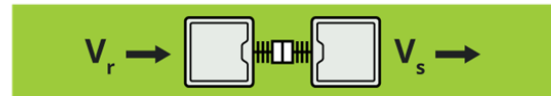

FILTRATION DETAILS

The SIAQ2-DIST1S utilizes a combined Particulate and Molecular filter to address defined design compounds:

CompleteAQ filter - SIAQ-CF1-20202

ASHRAE 52.2 rated to MERV 8

ASHRAE 145.2 rated for gas-phase contaminants

Unit achieves 2 years of filter life*

*Based on ASHRAE published generation rates for design compounds

OPTIONAL FEATURES

- Also available in Black (with additional lead-time)



smartIAQ GridSet Pro

Closed Loop Clean Air System

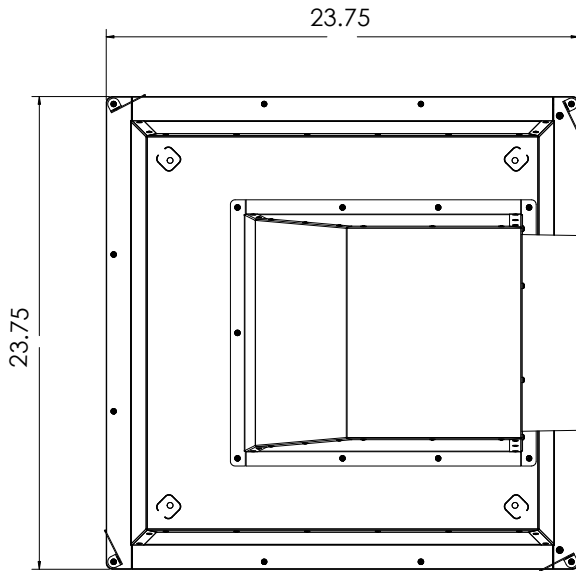

Plan View

Power/Control unit on Fan Module only

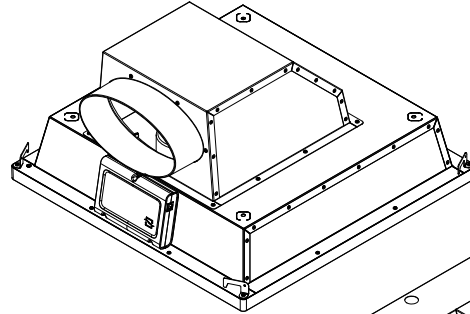

Fan Module

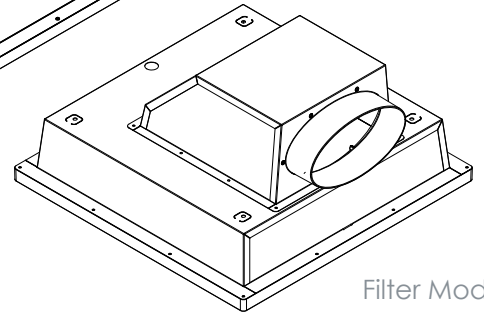

Filter Module

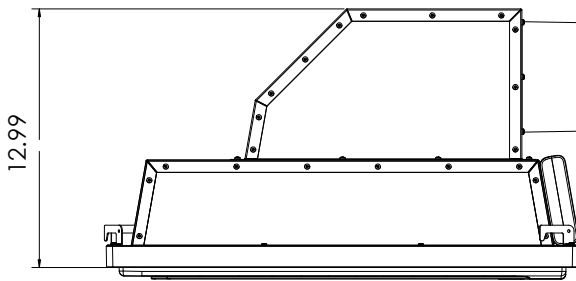

Side Elevation

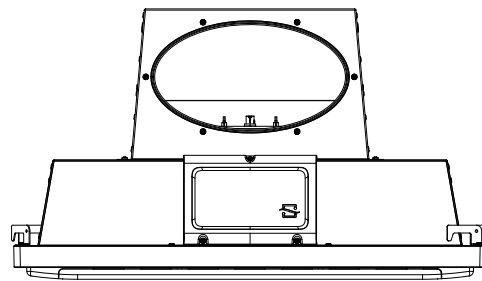

End Elevation

Overall dimensions representative of Fan and Filter Modules

SIAQ2-DIST: SPECIFICATIONS

Standard Input Voltage	48 VDC	Fan Module Weight	22.5lbs
Airflow Capacity	Up to 150 CFM	Filter Module Weight	18.6lbs
Sound Level** (Nominal Cleaning)	NC-25	Power Consumption	26 W (Max)
Filter Life*	2 years*	Temperature Range	0 - 140 F
Fan Module Dimensions (L x W x H)	23.75" x 23.75" x 12.2"	Humidity Range	5 - 85% RH (non-condensing)
Filter Module Dimensions (L x W x H)	23.75" x 23.75" x 12.2"	Compliance and Certifications#	UL 867, UL 2998, CARB

** 1m from unit, # Certifications Pending

© 2026 GPS Air

GPS Air is the owner of certain trademarks that appear in our materials. Please visit www.gpsair.com/trademarks for a list of our marks.

GPS-040-49-R23-5GSP