

smartIAQ GridSet Pro

smartIAQ® GridSet Pro™ Low Profile Hard Ceiling Mounted Unit

PRODUCT DESCRIPTION

smartIAQ® GridSet Pro™ is an on-demand air cleaner for commercial spaces. It supports the easy application of the Indoor Air Quality Procedure (IAQP) by extracting design compounds listed in ASHRAE Standard 62.1-2019, -2022 and -2025. With low voltage power, occupant-based response, and designed to install onto hard ceilings, smartIAQ GridSet delivers immediate return on investment and supports ongoing savings with low service, installation, and design costs. Standard-sized filters and the smartIAQ operating system provide 2 years of maintenance-free operation. Status indicator, air quality sensor, and filter access are in the space, ensuring confident ownership and maintenance. Integrates with end-user BMS system.

Suitable for classrooms, meeting rooms, retail stores, houses of worship, and some medical facilities, one smartIAQ GridSet cleans air in spaces up to 1,500ft². Multiple units may be used to help larger spaces achieve compliance.

STANDARD FEATURES

- Single piece cleaner construction for use with Included hard ceiling mounting frame
- Installs onto the surface of a hard ceiling, with fascia plates on all sides for a clean finish
- Integral EC Blower - varies up to a Peak Clean flow of 150CFM to allow outdoor air reduction
- Virtually silent operation - NC25 at max flow
- 48VDC low voltage power: uses CAT-5 or CAT-5e wiring to a smartIAQ Hub-4 Pro (separate device)
- Full BMS integration with native options for:
 - Modbus RTU - (via Hub-4 Pro)
 - BACnet MS/TP - (via Hub-4 Pro)
- Filter and operating profile provides closed loop for IAQP compliance
- Solid state motion and air quality sensors: no calibration or maintenance required:
 - Motion Sensor
 - CO2 Sensor
 - Formaldehyde Sensor
 - PM Sensor (1.0, 2.5, 4.0 & 10.0)
 - TVOC Sensor
 - NOX Sensor
- NPBI® Soft Ionization delivered to space at supply side



Single Zone

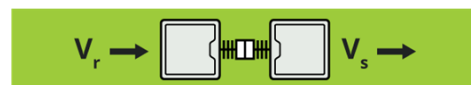

FILTRATION DETAILS

The SIAQ3-DIST utilizes a combined Particulate and Molecular filter to address defined design compounds:

CompleteAQ filter - SIAQ-CF1-20202

ASHRAE 52.2 rated to MERV 8

ASHRAE 145.2 rated for gas-phase contaminants

Unit achieves 2 years of filter life*

OPTIONAL FEATURES

- Also available in Black (with additional lead-time)

* Based on ASHRAE published generation rates for design compounds





smartIAQ® GridSet Pro™ Low Profile Hard Ceiling Mount

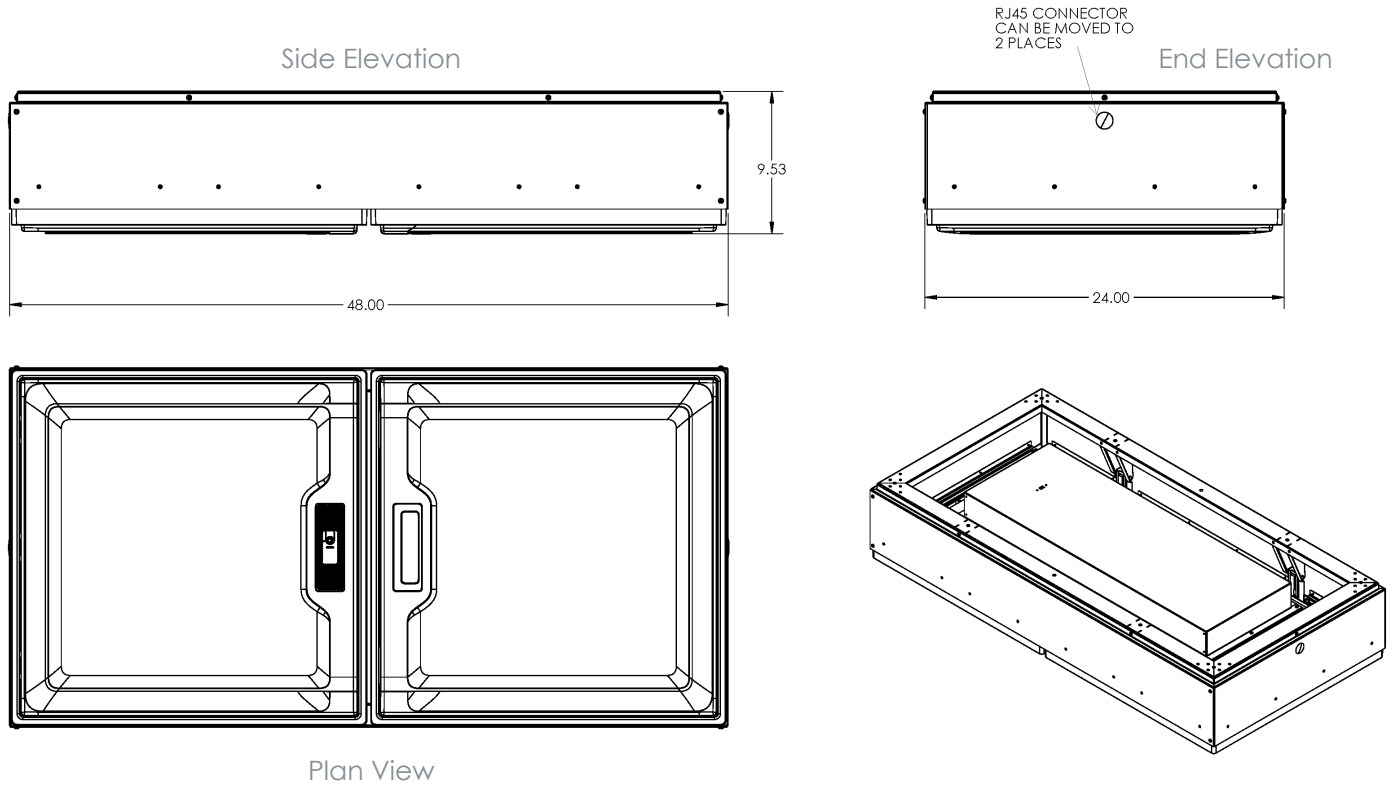

SIAQ3-DIST (Low-Profile): SPECIFICATIONS

Standard Input Voltage	48 VDC	Weight	Approx. 65 lbs
Airflow Capacity	Up to 150 CFM	Power Consumption	26 W
Sound Level** (Nominal Cleaning)	NC-25	Temperature Range	0 - 140 F
Filter Life	2 Years*	Humidity Range	5 - 85% RH (non-condensing)
Dimensions (L x W x H)	48" x 24" x 9.5"	Compliance and Certifications*	UL 867, CSA 22.2 #187, UL 2998, CARB

** 1m from unit

Certifications Pending

© 2026 GPS Air
GPS Air is the owner of certain trademarks that appear in our materials. Please visit www.gpsair.com/trademarks for a list of our marks.

GPS-040-53-R21-SGSPL



gpsair.com